

Investigation of the Wh-Movement in Jordanian Arabic: the case of Ammani Dialect

Bilal Ayed Alkhaza'leh
Shaqa University, Saudi Arabia
Walaa Hussein
University of Jordan

Abstract

There are many different ways to ask questions, either the formal written language or the informal spoken language which mostly deals with dialects. This study investigates the syntactic analysis of wh-construction patterns of one of the Jordanian dialects; in particular, it is the Ammani dialect. Ten young urban (Ammani) females were included in this case study; they were tested in natural atmosphere that allows them to ask freely without changing their way of speaking. It is claimed by the researchers that Ammani dialect includes eight question types; some of them include movements and others keep the wh-word in situ. It is also noticed that sometimes Jordanians can form questions using intonation rather than adding any wh-word. This paper investigates the cases where we have obligatory wh-movement, optionally wh-movement, wh-word in situ, and the rhythmically question forming.

Keywords: wh-movement; Jordan; Ammani dialect; situ; wh-construction patterns

1. Introduction:

Language is the most important way to express feelings and convey messages. There are many different ways to ask questions, either the formal written language or the informal spoken language which mostly deals with dialects. This paper is intended to be a contribution to syntacticians, especially those who are interested in studying syntax in terms of dialects; where a dialect is a particular form of a language that is specified to a particular social group or region.

People deal with the dialect as the local tongue or the variety of a specific group. Moreover, it is an aspect of human language that distinguishes populations mostly according to their residential areas. In Jordan, we have both the rural and urban dialects. In this piece of research, we are going to deal with a specific kind of the urban Jordanian dialect; the one used by people live in Amman, the capital of Jordan.

This paper investigates the wh-construction patterns in the Ammani dialect. According to Richards (2010) wh-movement occurs when prosody requires it and what language can do is predictable based on the position of its complementizer. A set of eight question types in Jordanian, Ammani Arabic (JAA) viz., **ki:f**; which means "how?", **ʔəj** "which?", **leIʃ** "why?", **məta:** "when?" **kəm** "how much/ how many?", **mi:n** "who?", **ʔef/ fu:** "what?", and **wein** "where?".

Moreover, there are some techniques for raising questions by using intonation in wh-word when they are in situ. The main common word order in JAA is by using a verb following by a subject (VS).

Sentence structure in JAA is divided into two types: on the one hand, we have the nonverbal sentences which are sentences with no verbs; in this case, questions can be asked with no verbs.

Example (1):

- **fu: ha:j?** "What is this?"
- **bI kəm ha:d?** "How much is this?"
- **leif heik?** "Why is it like this?"

On the other hand, the verbal sentences which are sentences with verbs, with VS word order, commonly.

Example (2):

- **ki:f dərəs ?Il kta:b?** "How did he study the book?"
- **dərəsIt fu:?** "What did you study?"
- **məta: dərəsIt?** "When did you study?"

As noticed above in the examples (1) and (2), questions are formed with two forms; initial, or final position (in situ) as shown in the diagrams below:

2-a

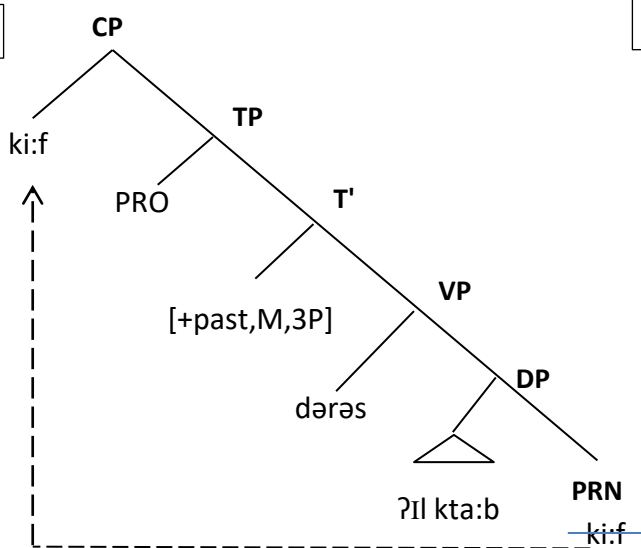

2-b

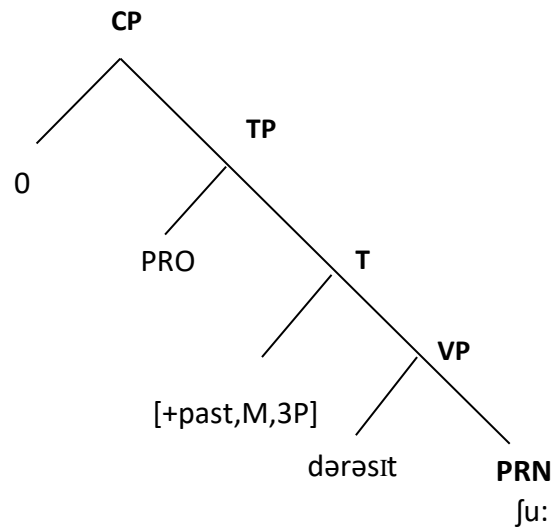

The diagram [2-a] shows that the wh-word is moved from its original position to the specifier of the complementiser phrase; in order to satisfy the Extend Projection Principle (**EPP**); which states that a head is required to have a specifier. Because the complementiser has a strong interrogative feature, it attracts the wh-word.

In the second diagram [2-b] the wh-expression stayed in its own position (Wh-in-situ construction), it keeps its properties, so it does not involve any movement; rather, it involves an intonation where the wh-word is stressed with a high tone in order to raise a question.

2. Research Questions:

- What are the used wh-words in Jordanian Ammani dialect?
- What are the wh-movement patterns in the Ammani dialect?

3. Theoretical Framework:

This research depends on the x-bar theory in drawing the trees. At the beginning, we used to use the flat structure to draw the trees (according to the binding theory); where there is no distinction between the words in terms of dominance or c-command. In other words; they are all 'flat' with respect to the head word (Carnie, 2006).

Example: (**The big book of poems with the blue cover**) is on the table.

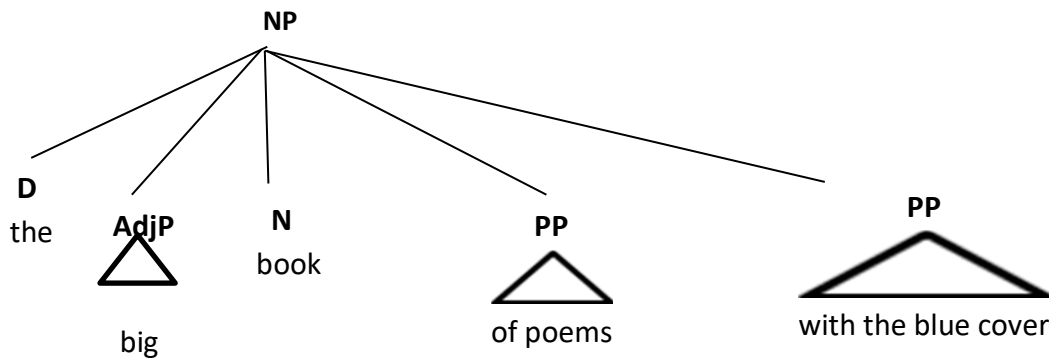

To organize the relationship between the phrases, the x-bar theory allows for more extended sentence structure trees and enables clearer perception of the sentence according to three main rules:

- Specifier Rule:** $XP \rightarrow (YP) X'$ or $XP \rightarrow X'(YP)$
- Adjunct Rule:** $X' \rightarrow X'(ZP)$ or $(ZP) X'$
- Complement Rule:** $X' \rightarrow X(WP)$ or $(WP) X$

Where the specifier is sister to X' , daughter of XP . The adjunct is sister to X' , daughter of X' . And the complement is sister to X , daughter of X' .

4. Related studies

Some studies have been conducted in Arabic field and in Jordanian field particularly to investigate wh movement. For example, Al- Momani (2010) examined the syntactic analysis of wh-phrases in Jordanian Arabic. The researcher assumes that movement of wh-phrases in JA from situ to initial position is either optional or obligatory. Yasin (2013) also investigates the wh-movement in Jordanian Arabic and Egyptian Arabic. Yasin suggests that wh-movement is prosodically driven. His paper also addresses wh-movement in Jordanian Arabic (JA) and Egyptian Arabic (EA): where the former moves the wh-phrase and the latter mostly leaves it in situ.

Sulaiman (2016) investigates the syntax of wh-questions in Syrian Arabic. She argues that standard Arabic (SA) has two sentence structures; the VSO and the SVO. She added that in the VSO order, the verb rises to a higher functional head and the subject rises to Spec TP. In the SVO order, the subject is attracted to its specifier. Therefore, due to the significance of this topic, this study examines the Ammani Jordanian dialect and tries to understand the used wh-words in Jordanian Ammani dialect and the wh-movement patterns in the Ammani dialect.

5. Method

Participants

Ten young female participants from University of Jordan were involved in the experiment. Their ages range from 20 to 24.

Procedures

The participants were motivated to ask questions while watching a movie. All participants had the chance to ask questions freely. While asking, the researcher recorded their ways of asking the question. After that, questions have been reviewed and discussed based on the objectives of the study.

6. Results and Discussions

The results are divided into eight parts according to the kind of wh- expressions: the first one is **ʔeʃ / ʃu:** "what?," people commonly prefer using them in simple sentences, in two positions, viz. first and final position.

Example (3):

- **ʔeʃ ? / ʃu:?** "What?"

This wh-word is used alone as a question, with a rising intonation to show surprise! During the experiment, the researcher told them that they will do many funny things, the first question was asked [**ʔeʃ ? / ʃu: ?**]; in order to ask them to repeat the statement.

Example (4):

- **ʔef ha:d?** "What is this?"

4-a

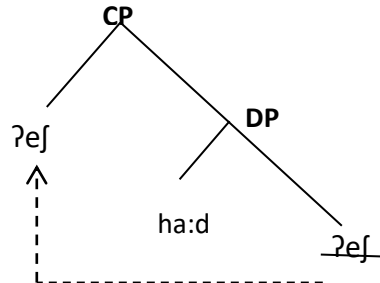

Here the sentence is nonverbal. The wh-word has fronted to the beginning of the sentence to satisfy the EPP of having the subject as a specifier of the complementiser phrase (CP). One piece of evidence for this movement is to use the coordination test.

4-b Sami saʔal: "ʔef ha:d? Wə ʔInəh ʔIli: Sa:r ju:?" "Sami asked: 'what is this? and what is happened?'"

4-b

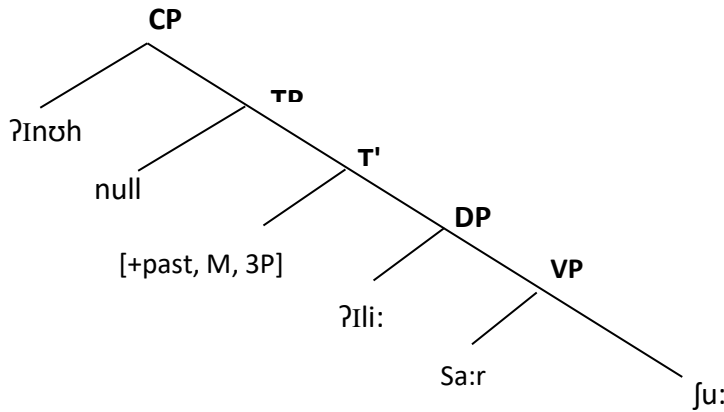

The above tree (4-b) shows that the wh-word (ju: "What?") did not move because the specifier of the CP is already occupied, there is the complementiser (ʔInəh). So, because the two sentences were coordinated, then they have the same category. However, when the sentence has a null complementiser, it attracts the wh-word to be fronted to the specifier of the complementiser phrase.

Another piece of evidence from their responses has both patterns.

Example (5)

- **ʔef lu:n ʔIssəja:rəh ?** "What is the colour of the car?"

- **lu:n ʔIssəja:rəh ʔef ?** "What is the colour of the car?"

Verbal sentences in Arabic are the most common patterns that use the form VSO (verb + subject + object) word order.

Example (6)

- **ʔef ʃIrIb ʔəhməd?** "What did Ahmad drink?"

- **ʃIbIt ʃu: ?** "What did you bring?"

In the previous examples, there are sentences with verbs, where the wh-words are used interchangeably with no constraints. Jordanian Arabic has a productive system to produce sentences, especially with questions.

The diagrams below show the structure of the sentences.

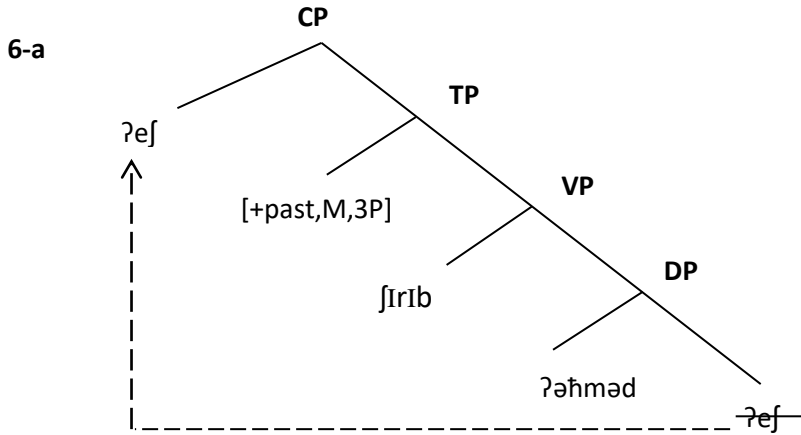

The above tree shows the syntactic structure of the sentence, the complementiser phrase has forced to form an interrogative sentence, so it attracts the wh-word to be the specifier of CP. The verb here has the property to have two arguments namely the doer, and what is drank replaced by the wh-word.

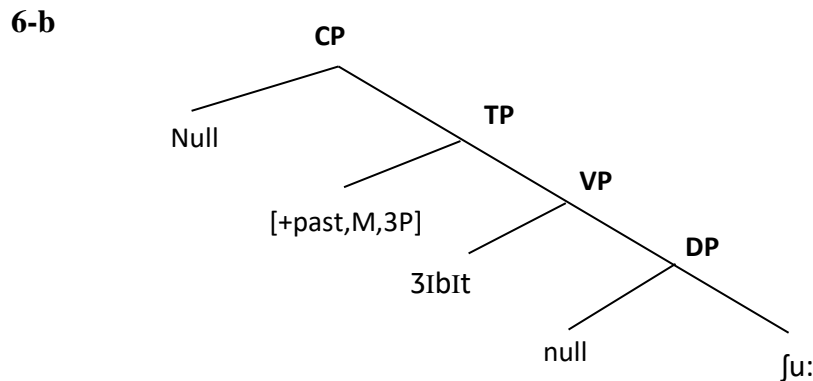

Here, the wh-word has no movement, with a null subject and a null complementiser. Simple forms are used widely in every day conversations' language. Moreover, the verb here has the property to have two arguments; the first one is the doer, which is represented by the null subject, and the second one what is brought appeared by the wh-word [ju:] "What?".

It was noticed that the appearance of the wh-word alone looks like a question form, with a good number of answers.

The second type of wh-words is [mi:n ?] "Who?", which is used for the animated objects, generally to answer questions about a person; in particular the doer of something. It is also used with nonverbal sentences.

Example 7:

- [mi:n ha:d ?] "Who is he?"
- [mitil mi:n?] "Like whom?"

The tree below represents the structure of the sentence:

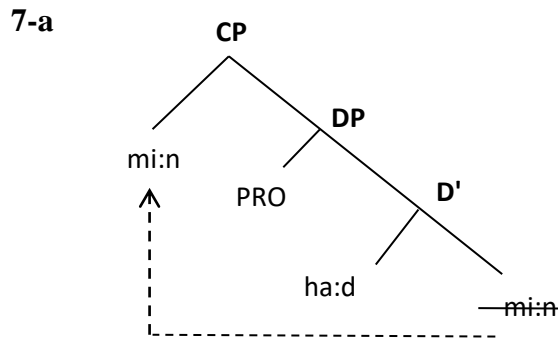

Here we have a sentence with no verb, with a movement of the wh-word to the very beginning of the phrase, the null complementiser has the force to have an interrogative sentence and attract the wh-word to be the specifier of the complementiser phrase. The wh-word originates in the final position but it is fronted by copying it to the beginning of the phrase.

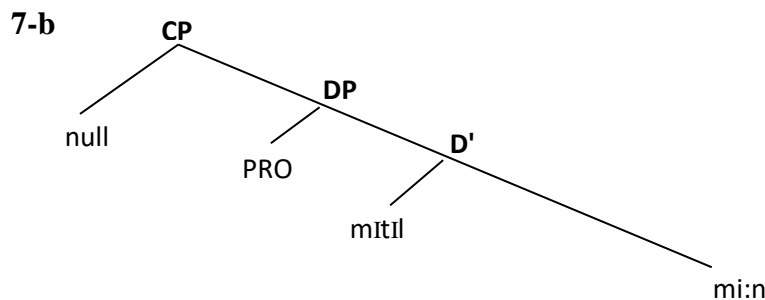

The pronoun (PRN) [mi:n?] "Who?" stayed in its position, with no movement, the question is raised by using the intonation, focused on the wh-word in the sentence.

The use of [mi:n] "Who ?" is in the verbal sentences.

Example 8:

- [mi:n kəsər ?II ka:sIh ?] "Who broke the glass?"
- [mi:n za:h ?II korsi: ?] "Who pulled the chair?"

In order to ask about the doer of something, in most of the answers, Jordanians use the wh-movement by fronting the wh-expression to be the specifier of the CP as shown in the diagrams below.

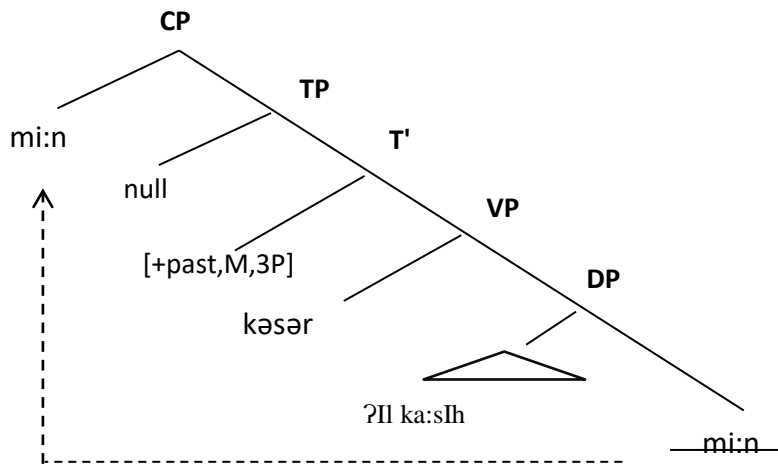
8-a

The verb [kəsər] "broke", as a predicate needs two arguments; the breaker who is the doer of the action in the above diagram (8-a); the doer is not spelled out, and what is broken in the above tree [?II ka:sIh] "the glass", which is the theme of the sentence. One answer from one participant who asked [mi:n?] "Who" with a high pitch.

The third type of wh-questions is [wein?] "Where". It is used to ask about animate and inanimate objects. To ask about the place, most of the participants used the nonverbal questions.

Example (9):

- [wein ?Ijʃəms ?] "Where is the sun?"
- [wein ?IrrIhIh ?] "Where is the trip?"
- [wein ?Issa:ʕə ?] "Where is the watch?"
- [wein ma:ma: ?] "Where is Mom?"

All of the previous examples have a wh-word movement from its original position to the specifier of the complementiser phrase.

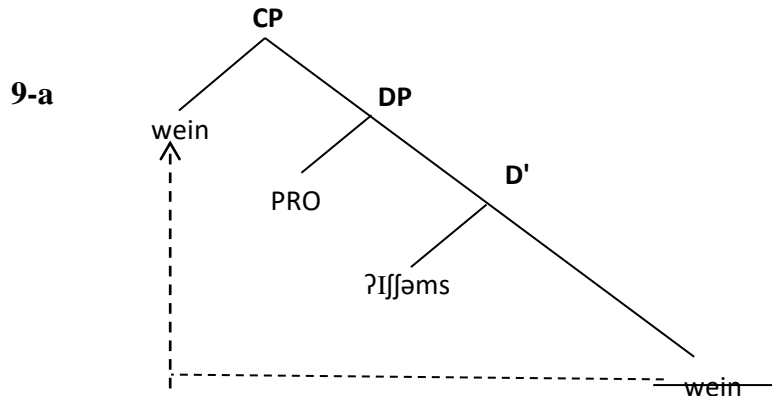

The complementiser has the force of giving the interrogative form to the phrase.

Some people give the question in situ with no movement, for example:

Example (10):

- [ba:ba: wein ?] "Where is dad?"
- [ʔɪl məsʝɪd wein ?] "Where is the mosque?"

10-a

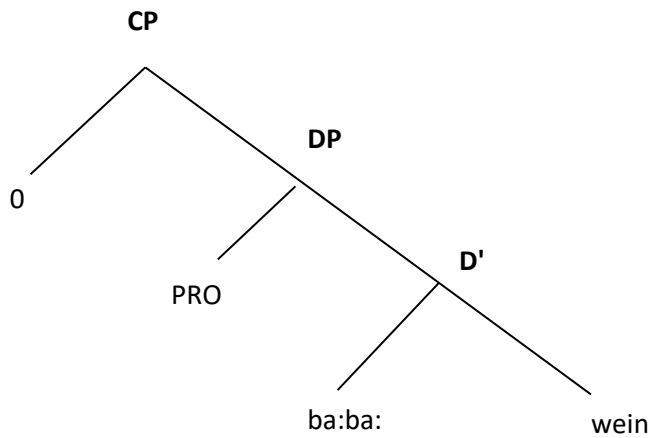

Example (11-a) illustrated that the wh-word moved to the beginning of the sentence, by the force of the complementiser phrase.

11-b

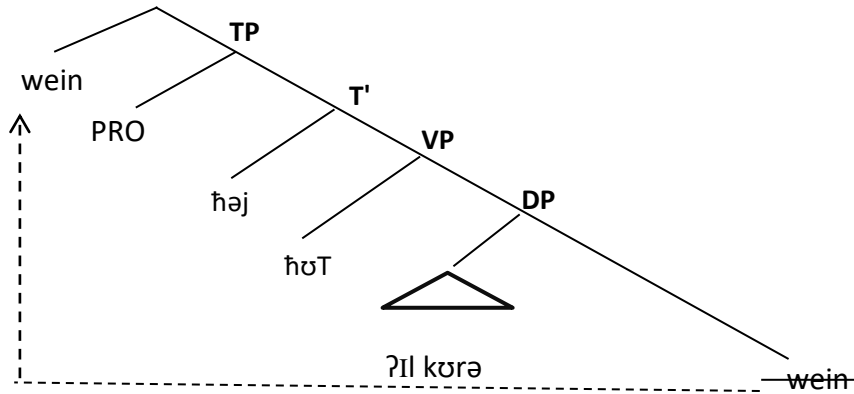

The above structure is a sample of the wh-movement to occupy the wh-word as a specifier of the complementiser because of the (C) feature of attracting it, because of its force to give an interrogative structure.

The fourth type of questions is [məta: ?] "When?"; which is used to ask about the time, with verbal sentences that mostly use wh-movement.

Example (12):

- [məta: ba:ba: ?Iʒa: ?] "When did my father come?"
- [məta: sa:fərət ?] "When did she travel?"
- [məta: hə nru:h nɪɪʃəb ?] "When we will go to play?"

12-a

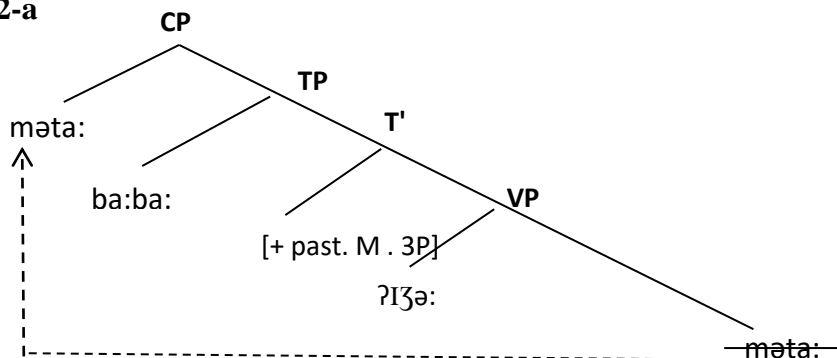

In the previous structure, the complementiser phrase gives the force, a discourse function of having an interrogative sentence. So, the wh-word [məta: ?] "When?" moved to be a specifier of CP. Actually, one participant said ' [məta: ba:ba: ?Iʒa: məta: ?] "When did my father come when?"

He repeats the wh-word [məta: ?] "When?" within the same sentence, the object is overt.

12-b

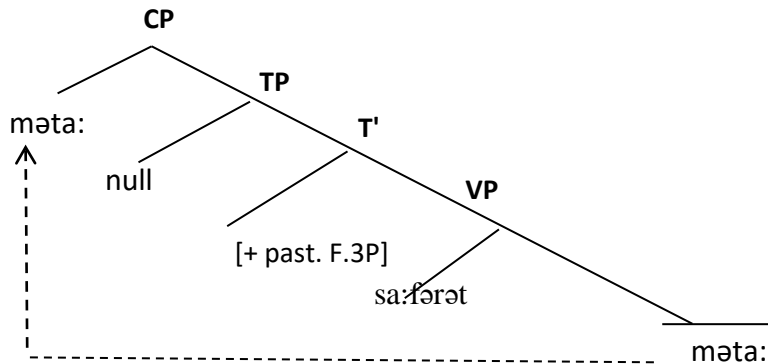

Then, patterns varied, one of them with an overt object like example 12-a, and others with no overt objects (covert objects). We also have wh-movement in [mətɑ: ?] "When?", which was fronted to the beginning of the sentence.

Another pattern of [mətɑ:] "when?" in situ, with no movement; where the wh-word keeps as a complement of the verb phrase (VP). It was observed that [mətɑ:] "When?" is only used with verbal sentences, for example:

Example (13):

- [ra:h məta: ?] "When did he go?"
- [ʕəli: hə jsa:fɪr məta: ?] "When will Ali travel?"

13-a

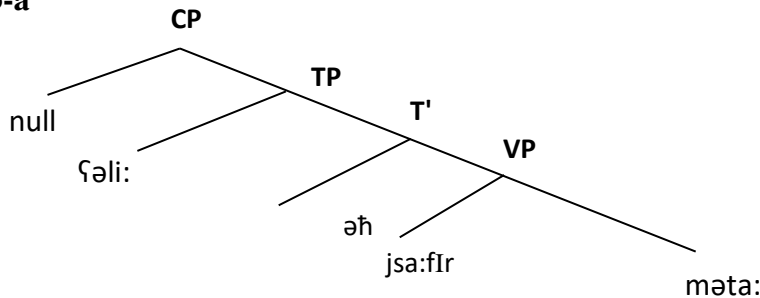

In the above diagram 13-a, the wh-word originated in its position as a complement of the VP, and in order to have a question pattern, the wh-word is stressed.

The fifth wh-word is [ʔəj ?] "Which?", and it is used for animate and inanimate objects. According to the responses, it was used within the two types of sentences; first with more common usages in nonverbal simple sentences, and the researchers observed that this type of

wh-word was not used in situ; it undergoes wh-movement in all the mentioned expressions. For example:

Example (14):

- [ʔəj lu:n ?] "Which colour?"
- [ʔəj kIta:b ?] "Which book?"

14-a

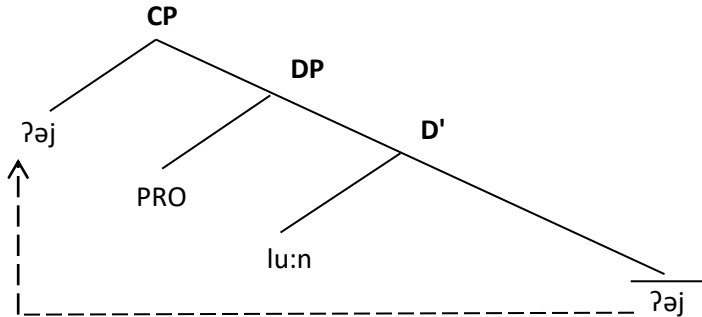

The previous diagram 14-a shows the movement of the wh-word to the specifier of CP position.

The second pattern is with verbal sentences, which is less frequent than nonverbal sentences. For example:

Example (15):

- [ʔəj wərəQə ʔəXəd ?] "Which paper did he take?"

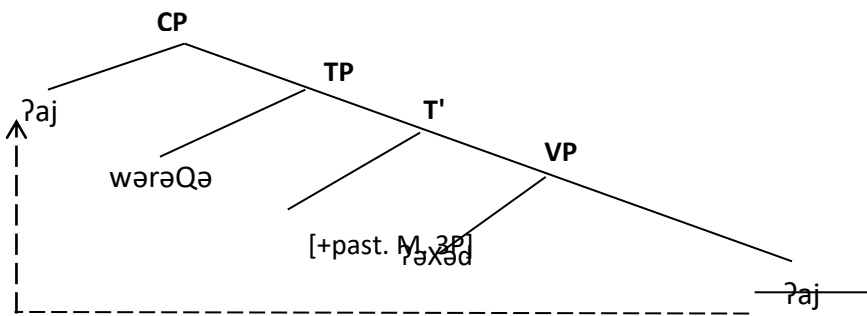

The previous diagram represents the wh-movement in a verbal sentence, examples 14-a and 15 give the researchers a piece of evidence that the wh-word is attracted to the position of the specifier of CP.

The sixth type of wh-words is [leIʃ ?] "Why?" that is used to talk about animate and inanimate objects. First in the verbal sentences interchangeably by fronting the wh-word or by keeping it in its position. For example:

Example (16):

- [leɪf ra:h ?] "Why did he go?"

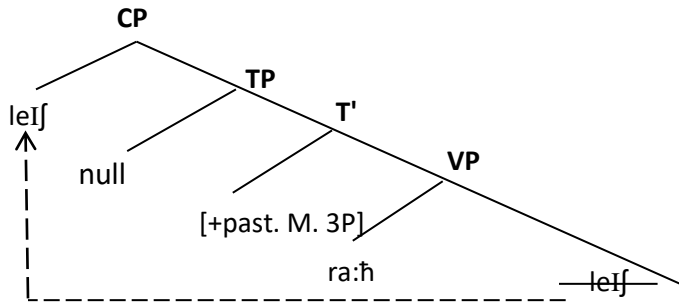

The diagram shows movement of the wh-word from its position to the position of spec CP.

Example (17):

- [ʔItʔəXXər leɪf ?] "Why is he late?"

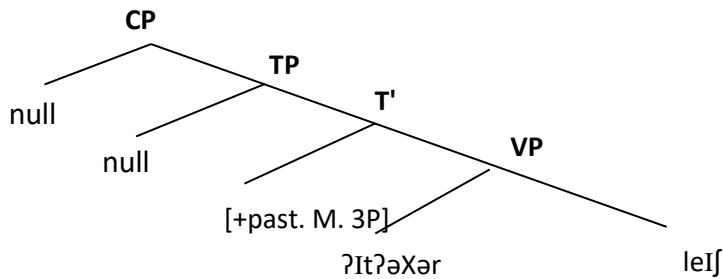

While in 17 the wh-word stays in its position, with a stress intonation on the wh-word.

The seventh wh-word is [ki:f ?], "How?" which is used to ask about animate and inanimate objects, for example:

Example (18):

- [ki:f ʔərsəm ?] "How do I draw?"

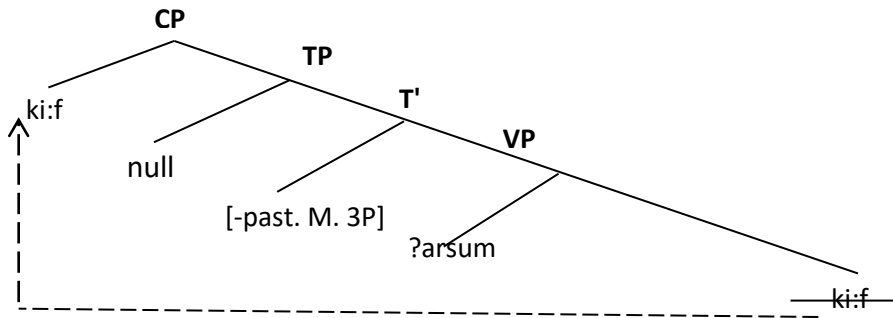

The wh-word is fronted to the position of the specifier of a complementiser phrase.

Example (19):

- [rətəbtha: ki:f ?] "How did you arrange it?"

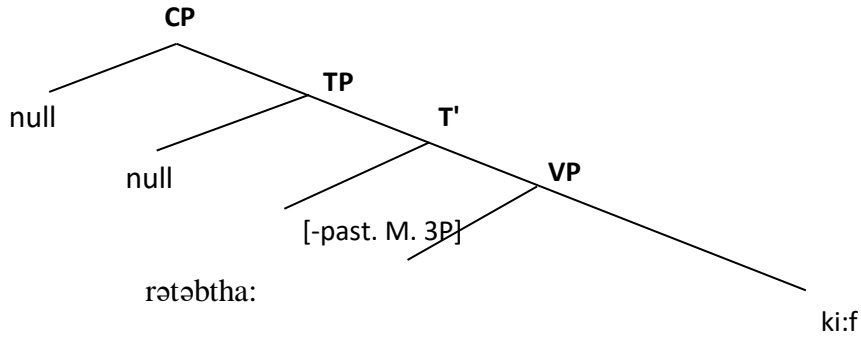

In the above example, the question is raised by stressing the wh-word which is in its position as the complement of the VP.

The eighth and last question word is [kəm ?] "How much? or How many?", which is used for both animate and inanimate sentences, and with nonverbal sentences, for example:

Example (20):

- [bI kəm ?II kta:b ?] "How much is the book?"

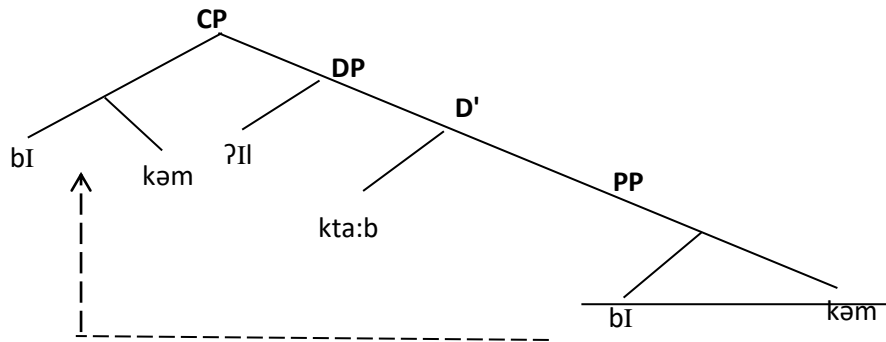

The structure in 20 shows that the maximal projection is moved to the position of the specifier of CP.

In order to satisfy the chain of uniformity condition, the whole phrase has been moved, not just the wh-word.

Secondly, the wh-question in situ which remains in its position with no movement.

Example (20):

- [ʒIbIt kəm ?] "How much did you get?"

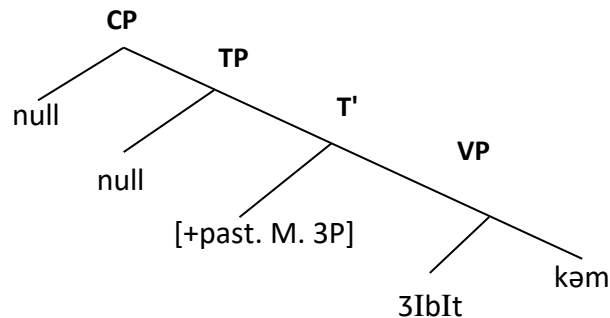

Here in the example, there is no wh-movement, but it is kept as a complement of the VP with a high pitch.

7. Conclusion

This paper discusses the derivation of the wh-question patterns in one of the Jordanian dialects; specifically, Ammani dialect. The participants were tested in a calm atmosphere in order to ask questions about different kinds of topics, they were shown their productivity, as good users of question forms and intonations. Some languages require wh-movement while other languages keep the wh-expressions in situ, the paper shows how Jordanian, Ammani dialect varies between these two positions.

References

- Al-Momani, I., & Al-Saiat, E. (2010). The syntax of wh-movement in Jordanian Arabic. *European Journal of Scientific Research*, 40(4), 584.
- Aoun, J. E., Benmamoun, E., & Choueiri, L. (2009). *The syntax of Arabic*. Cambridge University Press.
- Carnie, A. (2012). *Syntax: A generative introduction* (Vol. 16). John Wiley & Sons.
- Radford, A. (2009). *An introduction to English sentence structure*. Cambridge university press.
- Sulaiman, M. (2016). *The syntax of wh-questions in Syrian Arabic* (Doctoral dissertation, Newcastle University).
- Soltan, U. (2011). On issues of Arabic syntax: An essay in syntactic argumentation. *Brill's Journal of Afroasiatic Languages and Linguistics*, 3(1), 236-280.
- Yasin, A. (2013). Syntax-prosody interface: wh-movement in Jordanian Arabic and Egyptian Arabic.
- Richards, N. (2010). *Uttering trees* (Vol. 56). MIT Press.

Appendix 2:

The following table consists of the summary of the wh-words:

No	Wh- word	Gloss	Types of sentences	Wh-word position	Example
1	ʔeɪ/ fu:	What	Non-verbal	Beginning	[ʃu: ha:d ?] "What is this?"
				Ending	[ma:ma: ʔeɪ ?] "Mom, what?"
			Verbal	Beginning	[ʔeɪ ʃɪrɪb ʔəhməd ?] "What did Ahmad drink?"
				Ending	[jɪbɪt ʃu: ?] "What did you bring?"
2	mi:n	Who	Non-verbal	beginning	[mi:n ha:d ?] "Who is he?"
				Ending	[mɪtɪl mi:n ?] "Like whom?"
			Verbal	beginning	[mi:n kəsər ?ɪl ka:slh ?] "Who broke the glass?"
				Ending	-
3	weɪn	Where	Non-verbal	Beginning	[weɪn ʔɪʃfəms ?] "Where is the sun?"
				Ending	[ba:ba: weɪn ?] "Where is dad?"
			Verbal	Beginning	[weɪn ra:h ?] "Where did he go?"
				Ending	[weɪn həj hʊt ʔɪl kərə ?] "Where he will put the ball?"
4	məta:	When	Non-verbal	beginning	-
				Ending	-
			Verbal	beginning	[məta: ba:ba: ʔɪʒa: ?] "When di my father come?"
				Ending	[ʃəli: hə ʒa:flr məta: ?] "When will Ali travel?"
5	ʔəj	Which	Non-verbal	Beginning	[ʔəj lu:n] "Which color?"
				Ending	-
			Verbal	Beginning	[ʔəj wərəQə ʔəXəd ?] "Which paper did he take?"
				Ending	-
6	leɪf	Why	Non-verbal	beginning	-
				Ending	-
			Verbal	beginning	[leɪf ra:h ?] "Why did he go?"
				Ending	[ʔɪtʔəXXər leɪf ?] "Why is he late?"
7	ki:f	How	Non-verbal	Beginning	-
				Ending	-

			Verbal	Beginning	[ki:f ʔərsəm ?]	"How do I draw?"
				Ending	[rətəbθa: ki:f ?]	"How did you arrange it?"
8	kəm	How much / many	Non-verbal	beginning	[bɪ kəm ʔɪl kɪtə:b ?]	"How much is the book?"
				Ending	-	
			Verbal	beginning	-	
				Ending	[ʒɪbɪt kəm?]	"How much did you get?"